

ORC worlds trieste 2017

sailing instructions



Orc Worlds 2017
Trieste June 30 – July 8
Porto San Rocco, Muggia
info@orcworlds2017.com
www.orcworlds2017.com

Organizing authority
Yacht Club Porto San Rocco
Yacht Club Adriaco
Triestina della Vela
Circolo della Vela Muggia
Società Velica di Barcola e Grignano
TPK Circolo Nautico Triestino Sirena
Yachting Club Portorož

Yacht Club Porto San Rocco
strada per Lazzaretto 2
I-34015 Muggia (Ts)
t +39 040 273090
C.F. 90095960325
P.IVA 01057010322

under the auspices of the
Municipality of Muggia
Municipality of Trieste
Friuli Venezia Giulia Region
Chamber of Commerce Venezia Giulia
Trieste Port Authority
Government Commissioner in Friuli Venezia Giulia, Prefecture of Trieste

ORC Worlds Trieste 2017

1 **Organizing Authority**

The ORC Worlds Trieste 2017 is organized by the Yacht Club Porto San Rocco, in conjunction with Yacht Club Adriaco, Triestina della Vela, Società Velica di Barcola e Grignano, Circolo della Vela Muggia, TPK Circolo Nautico Triestino Sirena and Yachting Club Portoroz, under the authority of Federazione Italiana della Vela and under the overall authority of the Offshore Racing Congress (ORC) and World Sailing (WS).

2 **Rules**

2.1 The regatta will be governed by the rules as defined in The Racing Rules of Sailing (RRS).

2.2 The following rules will also apply:

- A. IMS Rule
- B. ORC Rating Systems Rule
- C. ORC Championship Rules
- D. World Sailing Offshore Special Regulations for Category 3 races with life raft only for offshore races

2.3 Italian National prescriptions, approved by World Sailing as par RRS 88.2, applies. All Italian competitors shall have a valid FIV association card for 2017, including a "type B" valid medical certification (i.e. Medical Certificate for Competitive Sports).

[DP] 2.4 Under RRS 87, ORC Rule 206 is changed as follows:

- A. All sails shall have been measured and stamped by an ORC measurer. During the pre-race equipment inspection, sails will be marked for the event by stamp, sticker and/or inspector's signature.
- B. The maximum number of sails shall be as defined in ORC Rule 206 with one additional mainsail allowed. The second mainsail shall have a minimum of one set of reef points. The mainsails may be interchangeable.
- C. With the exception of the second mainsail all sails shall be aboard while racing.
- D. Sails damaged during the series may be repaired. Sails beyond repair may be replaced with permission of the Technical Committee

2.5 If there is a conflict between languages the English text will take precedence.

2.6 Part 2 of the Racing Rules of Sailing is replaced by Part B of the International Regulations for Preventing Collisions at Sea from **20:00** to **05:00** local time (CEST).

[DP] 2.7 Appendix 1 of these SI shall apply for the bow numbers. In addition, one more event sponsor sticker must to be applied on each side of the forward part of the boom. Protests on the bow numbers can be lodged only by the Race Committee. This changes RRS 60.1, 60.3 and 60.4.

ORC worlds trieste 2017

3 **Classes**

Boats will be divided in Classes according to the Notice of Race requirements as follows:

Class A: $17.0 \geq \text{CDL} > 11.5$
Class B: $11.5 \geq \text{CDL} > 9.65$
Class C: $9.65 \geq \text{CDL} > 8.45$

Classes will have separate starts and separate results. Any change to CDL after applying ORC rule 305.2(b) shall not change the class that boat originally entered.

4 **Notices to competitors**

Notices to competitors will be posted on the official notice board located at Race Office in Porto San Rocco. Notices will also be posted on the event website: www.orcworlds2017.com. Failure or delay to post the notice on the event website will not be ground for request for redress by the boat. This changes RRS 60.1(b).

5 **Changes to Sailing Instructions**

Any change to the Sailing Instructions will be posted not later than **90 min** before it will take effect, except that any change to the schedule of races or the to the sailing area to be used by each class, will be posted by **20:00** on the day before it will take effect.

6 **Signals made ashore**

6.1 Signals made ashore will be displayed at **ORCWORLDS2017 Village in Porto San Rocco**.

6.2 When flag AP is displayed ashore '1 minute' is replaced with 'not less than **60** minutes' in race signal AP. This changes race signal AP.

7 **Schedule of races**

7.1 Times of the first warning signals are defined as follows:

02.07.2017	10:30	Skipper meeting
02.07.2017	13:00	Practice Race
03.07.2017	10:00	Skippers Meeting
03.07.2017	14:00	Offshore races
04.07.2017		Offshore races continued
05.07.2017	09:30	Skippers Meeting
05.07.2017	12:00	Inshore race(s)
06.07.2017	11:00	Inshore race(s)
07.07.2017	11:00	Inshore race(s)
08.07.2017	11:00	Inshore race(s)

The Organizing Authority and/or the Race Committee reserves the right to modify the above programme according to weather conditions and/or other unforeseen reasons.

ORC worlds Trieste 2017

Skipper meetings take place in the "Conference hall" near the Race Office and are limited to 2 persons for each boat.

15 minutes before the start, 4 sound signals will announce the meeting.

7.2 Nine races are scheduled including:

- two offshore races using the same starting line. The first race will be from the start to a control point approximately mid-course, and the second race will be from the start to the finish.
- seven inshore races

7.3 There will be no more than **3** races per day. Flag "**G**" displayed on the Finishing line means "There will be one more race after the one in progress." The Warning signal for the next race will be given one minute after lowering flag "**G**" with one sound.

7.4 On the last day of regatta no warning signal will be given after **15:30** unless it follows signal of general recall or postponement (Flag AP) of a race whose first warning signal had been made before **15:00**. In case of two classes sailing on the same course, the start of the second class will not be given after **16:00**.

8 **Class flag and Racing Area**

The Class flag(s) will be:

- Class A: White Flag with a capital letter "A"
- Class B: White Flag with a capital letter "B"
- Class C: White Flag with a capital letter "C"

Class A and Class C will race on the same sailing area; Class B will race on other sailing area.

Racing area "1" is located in Slovenian water, the RC boat will display a yellow flag with number "1"; Racing area "2" is located in Italian water, and the RC boat will display a yellow flag with number "2", see Attachment n. 1

9 **The Start**

9.1 Races will be started in the following class order: Class A and Class C; Class B races on a separated racing area. The Warning signal of the following class will be displayed at the earliest at the starting signal for the previous class, and may also be given while other classes are still racing.

9.2 A boat starting later than 4 minutes in the inshore races and 10 minutes in the offshore race(s) after her Start signal will be scored DNS. This changes RRS A4.1.

9.3 After signalling an individual recall, the race committee will attempt to broadcast the sail number, bow number or name of boat that has not started and is identified as OCS on VHF channel 72 (Class A+C) or 69 (Class B). Delay in the radio broadcast of these calls, or the order in which they are made, or any omission or failure in the emission or reception of these, will not be grounds for a request for redress by the boat. This changes RRS 60.1(b) and this rule does not reduce, modify or exonerate each boat's responsibility to start in accordance with the RRS.

ORC worlds trieste 2017

10 **Penalty system**

- 10.1 The penalty for breaking a rule of Part 2 while outside a Zone will be One-Turn penalty – one tack and one gybe. This changes RRS 44.1.
- 10.2 For the offshore race, RRS 28 is changed as follows:
- A. In rule 28.1, delete the first sentence and replace with:
 ‘A boat shall cross the starting line after having been entirely on the pre-start side at or after her starting signal and sail the course described in the sailing instructions and *finish*.’
 - B. In rule 28.2, delete the first sentence and replace with:
 ‘A string representing a boat’s track from the time she begins to approach the starting line from its pre-start side to cross it until she *finishes* shall, when drawn taut, ...’
 - C. Add new rule 28.3 Penalty:
 A boat that does not cross the starting line as required by rule 28.1 will receive the 20% scoring penalty as defined in RRS 44.3. This changes RRS A4 and A5. The scoring penalty shall be divided equally between offshore race 1 and offshore race 2, if offshore race 2 is completed.
- 10.4 The penalty points assigned in accordance with RRS A4.2 in an offshore race shall be applied only to offshore race 1 if a breach occurs before the mid-course control point and only to offshore race 2 if a breach occurs between the finishing lines of offshore race 1 and offshore race 2.
- 10.5 A measurement penalty shall apply fully to both offshore races.
- 10.6 For minor breaches of the Offshore Special Regulations, RRS 55 and any Sailing Instruction marked with **[DP]** the jury may impose any penalty different from Disqualification, or not impose a penalty, at its discretion. Maximum discretionary penalty for the minor infringements of the Offshore Special Regulations will be the scoring penalty of 10% calculated as in RRS 44.3(c).

11 **Protests and requests for redress**

- 11.1 In addition to complying with RRS 61, a protesting boat shall inform the Race Committee of her intention to protest and the identity of the protested boat(s) as soon as possible after finishing or retiring.
- 11.2 Protest forms are available at the race office. Protest shall be delivered there within the time limit which shall be:
- A. for inshore races: **2** hours after the last boat has finished the last race of day. The same time limit applies to protests by the race committee and international jury about incidents they observe in the racing area and to requests for redress (except as permitted in c) bellow). This changes RRS 61.3 and 62.2.
 - B. for offshore race(s): **2** hours after protestor’s finish. If a boat finishes by night, a protest can be logged from **09:00** until **10:00** of the next day.
- 11.3 Measurement protest by the boat shall not be accepted after 10:00 on 07.07.2017. This changes RRS 60.1(a) and 61.3.
- 11.4 Notice of protests by the Race Committee or the International Jury will be posted on the official notice board to inform competitors under RRS 61.1(b).

ORC worlds trieste 2017

- 11.5 Notices to inform competitors of hearings in which they are parties or named as witnesses will be posted:
- A. for windward/leeward races within 30 minutes of the protest time limit
 - B. for the offshore race, within 3 hours of the finish of all the boats involved in the protest, except that Protest notices will not be posted after 08:00 until 09:00 a.m. during the two days in which the offshore race is sailed.
- 11.6 On the last day of the regatta a request for reopening a hearing or request for redress for a jury decision shall be delivered:
- A. within the protest time limit if the party requesting reopening was informed of the decision on the previous day
 - B. no later than 30 minutes after the party requesting reopening was informed of the decision on that day
- This changes RRS 62.2 and 66.
- 11.7 When RRS N1.4(b) is applied the time limit will be 30 minutes after the decision is given.
- 11.8 The decisions of the International Jury will be final as provided in RRS 70.5.

12 **Scoring**

- 12.1 Windward/leeward race results will be determined by corrected times calculated by the Performance Curve Scoring.
- 12.2 Offshore race results will be determined by corrected times calculated by the method posted on the Notice Board at least 2 hours before the start.
- 12.3 The decision on the scoring method and scoring parameters used will be at the sole discretion of the Race Committee and together with length of course, directions of leg and the wind speed will not be grounds for request for redress by the boat. This changes RRS 60.1(b).
- 12.4 The championship is valid if at least 4 inshore races and 1 offshore race or at least 3 inshore races and 2 offshore races are completed. One discard will be allowed if 7 races are completed, but if there is only one offshore race completed in the series it shall not be discarded.

13 **Safety regulations**

- [DP] 13.1 Boats retiring for any reason in any race shall report to the Race Committee as soon as possible.
- [DP] 13.2 Any use of the engine for propulsion purposes for rescuing people, giving help or any other reason shall be reported after arrival in written form to the Race Committee stating reasons for such procedure. If a boat does not gain a significant advantage in the race, the International Jury may impose a discretionary penalty.

14 **Replacement of crew or equipment**

- [DP] 14.1 The International Jury may approve crew changes (adding new crew members, replacing or disembarking crew members) by written skipper's request made no

Orc worlds trieste 2017

later than **2** hour before the scheduled time of the start of the first race of the day. The substituted crew member shall not be aboard on any other competing boat throughout the remainder of the series. Crew substitutions in Corinthian Division shall also be valid World Sailing group 1 sailors. If not, the entry will be scored in the Open Division. All those limitation does not apply to the owner of the boat (or to the representative of company, of club, or to all kind of associations that own the boat).

- [DP] 14.2 Substitution of damaged or lost equipment will be not allowed unless approved by the Technical Committee. Requests for substitution shall be made to the Technical Committee at the first reasonable opportunity.

15 **Equipment and measurement checks**

A boat or equipment may be inspected at any time for compliance with class rules and Sailing Instructions. On the water or after arriving in harbour, a boat may be instructed by the measurer including VHF channel **72 (Racing Area A)** or **69 (Racing Area B)** to proceed immediately for inspection.

16 **Official boats**

- 16.1 Official boats will display a flag with a red letter "S" . Failure of any official boat to display her flag will not be grounds request for redress by the boat. This changes RRS 60.1(b).
- 16.2 Vessels used by press, photographers, film crews, VIPs etc. are not under the jurisdiction of the Race Committee. Any action by these boats shall not be ground for request for redress by the boat. This changes RRS 60.1(b).

[DP] **17** **Support boats**

Support boats shall be registered at the race office where identification number will be assigned. Identification shall be visible at all times. All support boats shall keep well clear of the starting area and, after the preparatory signal, are not to approach within 100 meters of any competing boat. A breach of this SI may result with a scoring penalty against the boat connected and/or withdrawal of permission to be in the racing area for one or more days.

[DP] **18** **Haul-out restriction**

From 09:00 on **30.06.2017** boats shall not be hauled out except for the purposes of repairing damage; and only after written permission from the International Jury. While hauled for this purpose, cleaning and polishing of the hull below the waterline will not be permitted. Appendages shall not be removed from the boat during the series.

19 **Communication**

- 19.1 Radio communication with Race Committee during the regatta will be on VHF channel **72 (Class A+C)** or **69 (Class B)**. The Race Committee may give verbal confirmation of any race signal over the same VHF Channel. Failure to make a broadcast or to time it accurately will not not be grounds for request for redress by the boat. This changes RRS 60.1(b).

ORC worlds trieste 2017

- [DP] 19.2 Except when communicating with the race committee, a boat while racing, shall not transmit or receive communication of any information not publicly available to all boats participating. This changes RRS 41.

20 **Trophies and prizes**

Prizes will be presented as follows:

- A trophy for the World Champion in each class.
- Prizes for the boats scoring 2nd and 3rd in each class.
- A prize for the Corinthian Division World Champion in each class.

The organising authority may also present additional prizes. The complete list of trophies and prizes will be posted on the official notice board before the start of racing.

21 **Disclaimer of liability**

Competitors participate in the regatta entirely at their own risk, see RRS 4 - Decision to Race. The Organizing Authority, ORC and any other party involved in the organization of the regatta will not accept any liability for material damage or personal injury or death sustained in conjunction with or prior to, during, or after the regatta. Each boat owner or his representative accepts these terms by signing the entry form.

Part 2 - Inshore course

23 **The course**

- 23.1 The diagram in Attachment 2 shows the course, including the approximate angles between legs, the order in which marks are to be passed, and the side on which each mark is to be passed.
- 23.2 No later than the warning signal, the RC signal boat will display the approximate compass bearing of the first leg.

24 **Marks**

- 24.1 Class A and Class C course: marks 1 – 2- 3S/3P will be orange tetrahedral inflatable buoy, ILM and finishing mark will be yellow cylindrical inflatable buoy; new mark as per RRS 33 will be orange tetrahedral inflatable buoy with a coloured band.
- 24.2 Class B: marks 1 – 2- will be orange cylindrical inflatable buoy , 3S/3P will be red cylindrical inflatable buoy, ILM and finishing mark will be yellow cylindrical inflatable buoy; new mark as per RRS 33 will be orange cylindrical inflatable buoy with a coloured band.

25 **Change of the next leg of the course**

To change the next leg of the course, the race committee will lay a new mark and

ORC worlds trieste 2017

remove the original mark as soon as practicable. A new windward mark will be placed without the offset mark.

26 **Starting line**

26.1 The starting line will be between the staff displaying an orange flag on the Race Committee Boat at the starboard and the staff displaying an orange flag on the pin end boat at the port-end.

[DP] 26.2 Near the starboard end of the starting line a Mark ILM may be used, which shall be left to starboard while starting. Marks ILM is a starting mark as prescribed in the Preamble to RRS, Part 2, Section C. A boat shall not sail between the inner limit mark (ILM) and the committee boat at any time after her warning signal has been made.

27 **Finishing line**

The finishing line will be between the staff displaying a blue flag on the Race Committee Boat and the finishing mark.

28 **Time limit**

The time limit for the first boat to finish will be 2 hours . Boats failing to finish within **30 minutes** after the first boat sails the course and finishes will be scored Did Not Finish. This changes RRS 35 and A4.

[DP] **29** **Tracking system**

29.1 GPS tracking of individual boats will be used for safety purposes; each boat must carry the tracking device given by the OA during the races. It must be switched on and positioned near the backstay or on the top of the deck. The organizers will use the Trac Trac system for public media purposes and to provide displays onshore.

The following safety procedure will be followed:

- A. At registration, the Safety Officers, shall personally collect and sign for their tracking device.
- B. The tracking device must be returned to the Race Office at the end of the last race of the day to be recharged. It is a Safety Officers responsibility to re-charge every evening the tracking device.
- C. The tracking device must be returned to the Race Office at the end of the last race of the series and before the Prize Giving.
- D. Any boat failing to comply with this procedure, without any reason beyond her control, will be reported to the Race Committee and/or Protest Committee for possible action.
- E. In case of loss, the cost will be charged.

Part 3 - Offshore course

31 The course

The course will be announced on 3rd June 2017 during the planned skipper meeting and posted on the Notice Board at the end of the meeting.

The offshore race will be scored as two races: the first offshore race will be from the Start in to the First finish line located in front of Pirano, and the Second offshore race will be from the Start to the Second finish line. The outermost point to round will be "Sv. Ivan Na Pucini" in the Croatian Waters.

32 Marks

Marks **will be announced during the skipper meeting.**

33 Windward mark

The RC may set a windward mark to obtain a start to windward, if necessary. If the windward mark is set, it will be approximately two nautical miles from the starting area and the RC will, before the warning signal, display a **Red flag** which indicates the mark shall be left to port, or a **Green flag** indicating the mark shall be left to starboard.

34 Starting line

34.1 The Starting line will be between the staff displaying an orange flag on the Race Committee Boat at the starboard and the staff displaying an orange flag on the pin end boat at the port-end.

[DP] 34.2 Near the starboard end of the starting line a Mark ILM may be used, which shall be left to starboard while starting. Marks ILM is a starting mark as prescribed in the Preamble to RRS, Part 2, Section C. A boat shall not sail between the inner limit mark (ILM) and the committee boat at any time after her warning signal has been made.

35 Finishing line

35.1 The Finishing line for the first offshore race will be announced during the planned skipper meeting.

35.2 The Finishing line for the second offshore race will be between the staff displaying a blue flag on the Race Committee Boat at and the staff displaying a blue flag on the pin end boat.

36 Time limit

36.1 There will be no time limit for the first offshore race.

36.2 The time limit for first boat to finish **will be announced during the meeting.**

ORC worlds Trieste 2017

[DP] 37

Finishing by night

Boats that finish by night shall illuminate their numbers when finishing, and communicate on VHF **Channel 72** (for all boats) their sailing number to the RC; in case of doubt shall try to identify themselves to the RC after finishing.

[DP] 38

Reporting positions

All boat must send an sms to the number +39 3356123200 in the moment it crosses the first finishing line and in the moment it crosses the second finishing line. This message will be used only to report the order in which boats finish a race, but not his real time. The content of the message has to be: "sailing number, first (or second) finish, hour in day, hh.mm.ss".

39

Tracking system

39.1

Ref. to SI 29.1

ORC worlds trieste 2017

APPENDIX 1 BOW NUMBERS

Bow numbers shall be placed as forward as possible

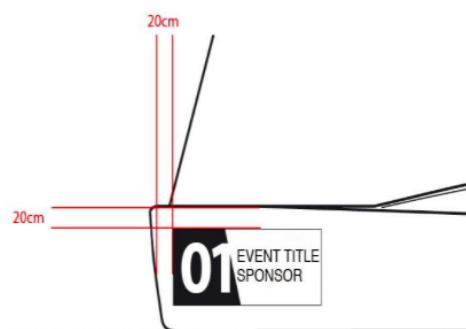
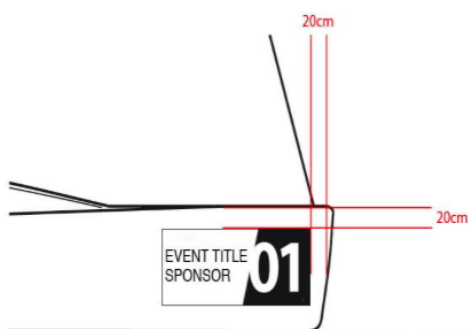

Correct



Not Correct



ORC Worlds Trieste 2017

ATTACHMENT N. 1 RACING AREAS

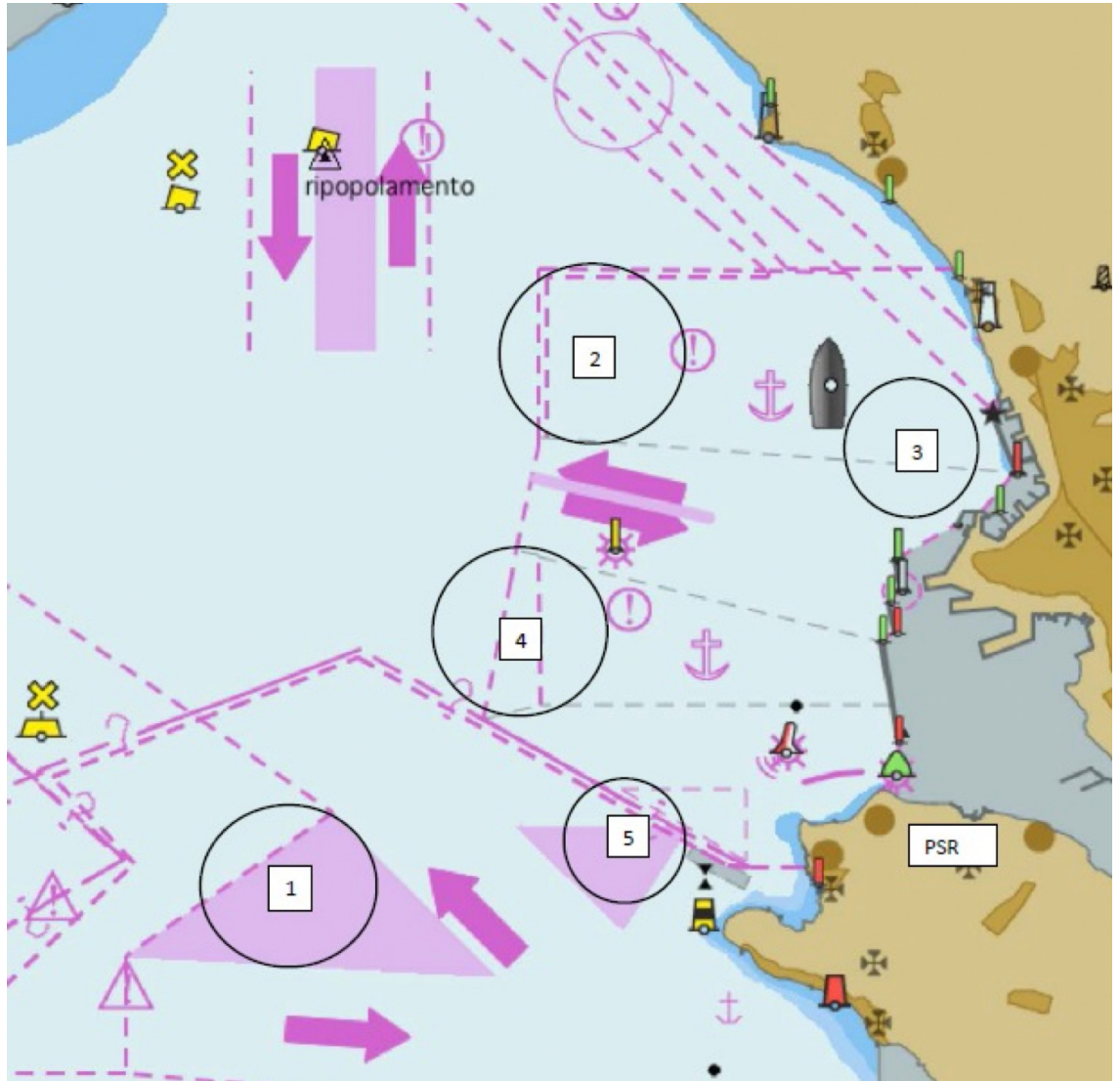

Racing Area 1 and 2 will be used.
Racing Area 3, 4, and 5 are additional and spare

ATTACHMENT N. 2 INSHORE COURSE DIAGRAM

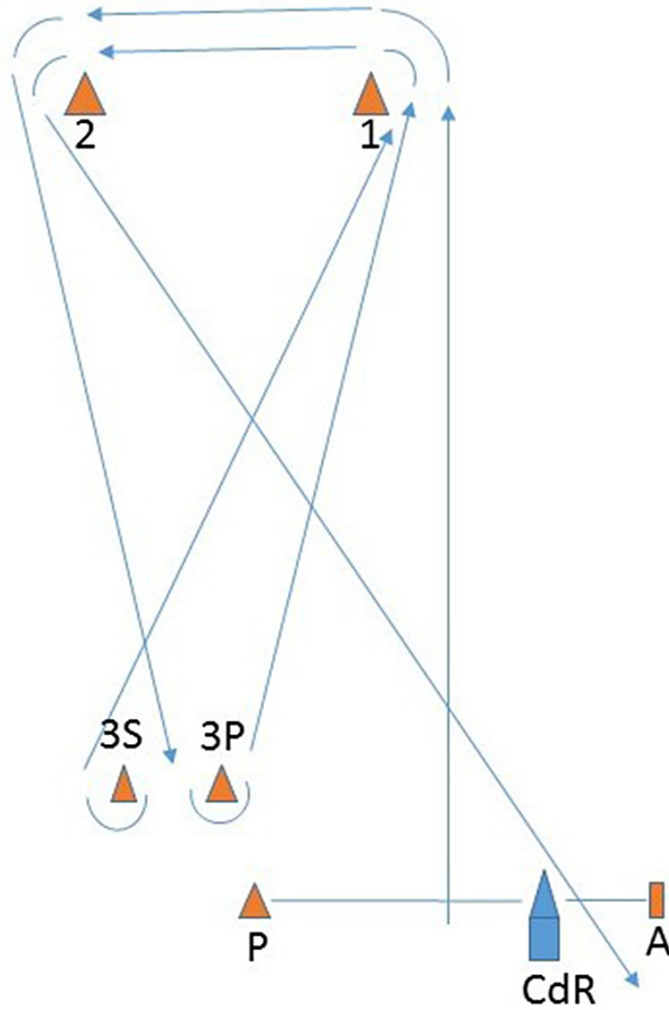

Mark 3S and 3P constitute the gate. If one mark is missing the other one shall be left to port; this change RRS 34.

CLASS A - course: Start - 1 - 2 - 3S/3P - 1 - 2 - 3S/3P - 1 - 2 - Finish
CLASS B - course: Start - 1 - 2 - 3S/3P - 1 - 2 - Finish
CLASS C - course: Start - 1 - 2 - 3S/3P - 1 - 2 - Finish